



Air velocity sensor

QVM62.1

Use

This sensor is used to control the air velocity to a constant value, or to balance out pressure fluctuations (supply or extract air control), or to monitor the flow in air ducts. It primarily is used for modulating fan control in primary plants to set the basic volume flow.

Action

The QVM62.1 records the air velocity as a measured value and converts it to an active DC 0...10 V or 4...20 mA output signal.

Three measuring ranges are available:

0...5 m/s, 0...10 m/s, and 0...15 m/s.

The sensor measures a point, i.e., it measures the values at a specific location in the flow profile. For recording the mean air velocity in the duct, the sensor's immersion depth is the key measure. The immersion depth depends on the flow profile.

The measurement principle is based on the anemometric measurement principle.

The specially developed thin film sensing element of the QVM62.1 is to a big extent independent from the flow direction and is nearly insensitive to any kind of dirt in the airflow.

Ordering

When ordering, indicate the name and type designation :

Air velocity sensor **QVM62.1**

The air velocity sensor consists of:

- Immersion stem with sensor head and sensing element
- Extension pipe with fitting
- Immersion stem end with flow direction arrow
- Adjustable connecting flange
- Transducer
- Connection cable, screened, four-core, 1 m long

A scale with 0.5 cm grating on the immersion stem and the extension pipe indicates the immersion depth.

The connecting flange is used to attach and seal the immersion stem on the duct wall.

A plastic housing with removable cover accommodates the transducer. It can be screwed to a flat surface.

The sensor cable is connected; the sensor and the transducer together represent a unit. The measuring ranges are selected by inserting or removing a plug-in jumper.

- Protection against false wiring is provided related to own voltages, i.e., measuring output X1 is short-circuit proof.

The sensor head connections are not protected against AC/DC 24 V operating voltage.

Wiring and setting elements

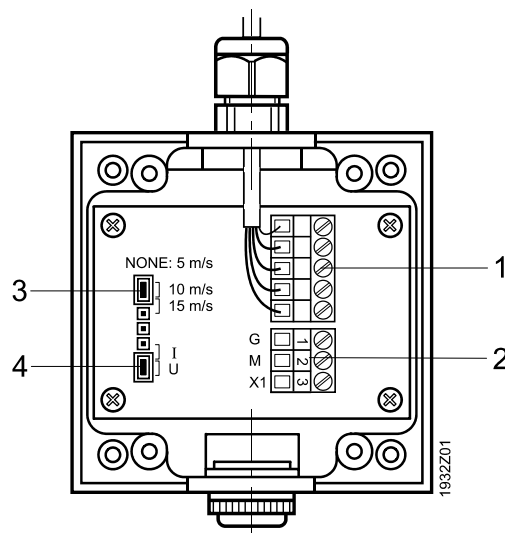

- 1 Terminal block for connection to the immersion stem
- 2 Terminal block for connection to controller
- 3 Plug-in unit for setting the three velocity ranges. The following applies:
 No plug-in jumper = 0...5 m/s
 Plug-in jumper on 1 and 2 = 0...10 m/s (factory setting)
 Plug-in jumper on 2 and 3 = 0...15 m/s
- 4 Terminal block for selection of the output signal:
 Pos I = DC 4...20 mA
 Pos U = DC 0...10 V

Technical data

Power supply	Operating voltage	AC/DC 24 V \pm 20 %
	Frequency	50/60 Hz
	Power consumption	\leq 5 VA (max. 200 mA)
Measuring data	Measuring ranges, adjustable	0...5 m/s 0...10 m/s (factory setting) 0...15 m/s
	Measuring accuracy at 20 °C, 45 % r.h., 1013 hPa	
	0...5 m/s	\pm (0.2 m/s + 3 % of measured value)
	0...10 m/s	\pm (0.2 m/s + 3 % of measured value)
	0...15 m/s	\pm (0.2 m/s + 3 % of measured value)
	Permissible air velocity	20 m/s
	Direction dependence	<0.3 % of measured value at \leq 10°
	Time constant t_{90} at 10 m/s	ca. 4 s
Signal output X1	Voltage output	DC 0...10 V, \pm 1 mA
	Current output	DC 4...20 mA, 0...500 Ω

Line length	Perm. line length to controller at	
	0.6 mm dia copper cable	50 m
	1 mm ² copper cable	150 m
	1.5 mm ² copper cable	300 m
Connections	Line length to the sensor head	1 m (prewired)
	Mechanical:	screw connection
Degree of protection	Electric:	screw terminal, max. 2 × 1.5 mm ²
	Degree of protection provided	
Environmental conditions	by enclosures as per EN 60 529	
	Transducer	IP 42
	Sensor head	IP 20
	Degree of protection as per EN 60 730	III
	Operation (transducer and immersion stem)	IEC 721-3-3
	Climatic conditions	class 3K5
	Temperature	-10...+45 °C
	Humidity (non-condensing)	<95 % r.h.
	Mechanical conditions	class 3M2
	Chemical conditions	class 3C2
Materials and colours	Storage (transducer and immersion stem)	IEC 721-3-1
	Climatic conditions	class 1K3
	Temperature	-30...+60 °C
	Humidity (non-condensing)	<95 % r.h.
	Mechanical conditions	class 1M2
	Transport (transducer and immersion stem)	IEC 721-3-2
	Climatic conditions	class 2K3
	Temperature	-25...+60 °C
	Humidity (non-condensing)	<95 % r.h.
	Mechanical conditions	class 2M2
Standards and directives	Housing bottom	polycarbonat, RAL 7001 (silver-grey)
	Housing cover	polycarbonat, RAL 7035 (light-grey)
	Sensor pipes	polycarbonat, RAL 7001 (silver-grey)
	Sensor head, extension, end	polycarbonat, RAL 7035 (light-grey)
	Connecting flange	polycarbonat, RAL 7001 (silver-grey)
	Sensor, total	silicon-free
Weight	Product standard	
	Automatic electrical controls for household and similar use	EN 60730-1
	Electromagnetic compatibility	
	Immunity	EN 61000-6-2
	Emissions	EN 61000-6-3
Weight	CE conformity	
	Electromagnetic compatibility	2004/108/EC
Weight	With packaging	0.352 kg

Engineering notes

Place the sensor on the measuring path in a location where the air flow is quiet. Thus: do not place it close to dampers, registers, and duct direction changes.

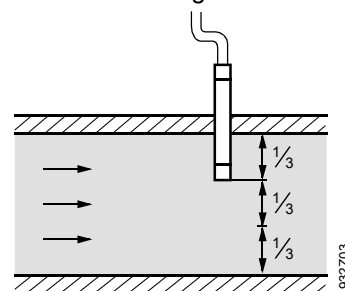
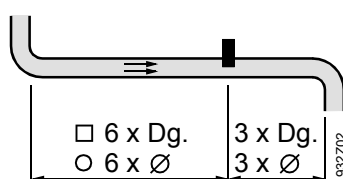

Use a transformer with safety extra-low voltage (SELV) with separate winding for 100% ON-time. Observe all local safety rules and regulations pertaining to sizing and protecting transformers.
 Note the permissible line length to the controller.

Mounting and installation notes

Mount the immersion stem so that the air flows through the opening at the sensor head. The immersion stem is premounted and wired to the transducer on delivery. The sensor pipes and the end with the direction arrow are prearranged on the connecting cable-fit them together (use the direction-oriented snap-on connections). If the extension pipe is not required, remove it from the cable. The connecting flange is not attached on delivery.

The sensor is supplied with mounting instructions.

Commissioning notes

Check the wiring and the air velocity range settings prior to commissioning.
 Check the immersion stem position in the air duct (mounting instructions!).

Diagrams

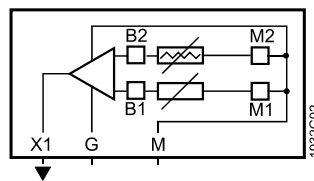

- G Operating voltage AC/DC 24 V
- M Measuring neutral/operating voltage ground
- X1 Output signal DC 0...10 V or 4...20 mA

Dimensions (All dimensions in mm)

