



Differential Pressure Sensor

QBE64-DP4

for neutral and mildly corrosive liquids and gases

Differential pressure sensor, suitable for gases or liquids, for the measurement of positive or negative pressures and pressure differentials in HVAC systems.

- **Measuring system based on ceramic lever technology**
- **Simple, robust construction for highly reliable operation**
- **For neutral and mildly corrosive liquids and gases**
- **Supply voltage AC 24 V or DC 18...33 V**
- **DC 0...10 V output signal**
- **Male-threaded G^{1/8}" connection**
- **Delivery includes 2 screwed fittings for copper pipes, 6 mm diameter**

Use

The QBE64-DP4 differential pressure sensor is particularly suitable for use in HVAC systems for continuous monitoring of the level or flow rate of neutral or mildly corrosive gases or liquids.

The pressure to be monitored acts on a ceramic sensor element. The measured pressure is converted electronically into a linear DC 0 ...10 V output signal.

Ordering and delivery

When ordering, please specify the quantity, product name and type code.

Example: 1 differential pressure sensor QBE64-DP4

A suitable fixing bracket is supplied with the sensor.

Any accessories required must be ordered separately.

Compatibility

The QBE64-DP4 differential pressure sensors can be used in conjunction with all devices or systems capable of processing the DC 0...10 V output signal.

Technology

The pressure to be monitored acts on a ceramic sensor element. The ceramic element has the following significant advantages

- Very low susceptibility to temperature
- Resistance to high temperature
- No mechanical ageing or creepage

The sensor signal is linearised, temperature-compensated and amplified by the sensor electronics.

Mechanical design

The QBE64.DP4 differential pressure sensor comprises the following:

- Sensor cover with connecting cable and gland
- Pressure sensor casing with ceramic element, screw connections and purging points
- Printed circuit board
- 2 screwed fittings for copper pipe, 6 mm diameter
- Fixing bracket, enclosed loose, with sensor

Accessories

AQB2002 Mounting kit for remote mounting with 1 m copper capillary line, both ends prefabricated ready for connection. Thread adapters and terminal nuts made of brass. Pressure connection with G1/8" or G1/2" outer threading.

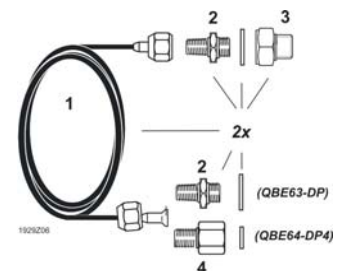

Mounting instructions

Mounting instructions are enclosed with the differential pressure sensor.

The QBE64-DP4 sensor can be connected directly with R $\frac{1}{8}$ " screwed fittings. Special precautions must be taken on site when mounting the sensors to ensure airtight screw connections.

Recommended measures

- Use standard T-fittings or drill and de-bur measuring holes, each 5 mm diameter, for the pressure tapping points (A).
- An isolating bypass (5) can be fitted, to avoid overloading the pressure sensor on one side while making adjustments.
- For inspection purposes, measuring circuits can be fitted with a measuring-T at the sensor head.

Important note

Mounting for use with liquids:

- Always mount the sensor lower than the pressure measuring points
- Mount on a vibration-free surface
- Always evacuate the system

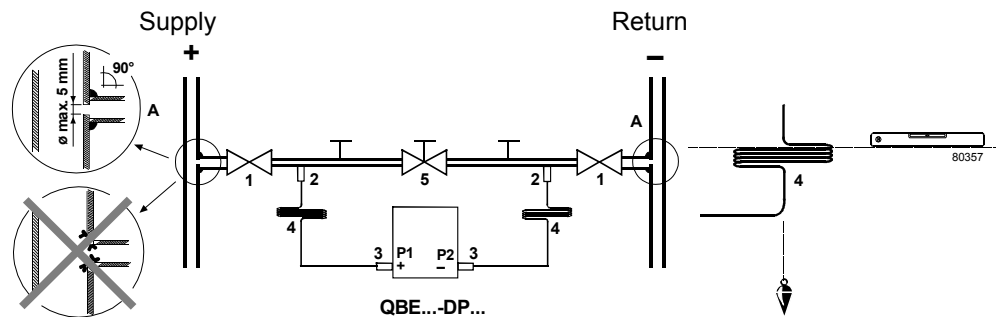



- Key:
- A Measuring holes
 - 1 Isolating valves
 - 2 T-joints
 - 3 Connection pieces (from mounting kit AQB 2002)
 - 4 Copper pipes (from mounting kit AQB 2002)
 - 5 Isolating bypass



Remote mounting

For remote mounting, the sensor can be operated together with the AQB pressure mounting kit in ambient temperatures of up to 70 °C for medium temperatures of up to 180 °C. Care must be taken in this case to ensure that the cooling efficiency of the copper pipe is not reduced by additional heat sources or by restrictions to the air circulation.

Technical data

Electrical interface	Power supply	Low voltage (SELV, PELV)
	Operating voltage	AC 24 V ± 15 %, 50/60 Hz or DC 18...33 V
	Current consumption	with AC 24 V: < 5 mA with maximum output signal
	Output signal	DC 0...10 V, short-circuit-proof and proof polarity reversal
Product data	Working resistance	> 10 kΩ
	Differential pressure range	0 ... 4 bar
	Measuring element	Ceramic
	Measuring accuracy	Factory calibrated
	Sum of linearity, hysteresis and repeatability	< ±0.5 % FS (FS = Full Scale)
	Zero point, Full scale	< ±0.4 % FS
	TC zero point	< ±0.04 % FS/K
	TC sensitivity	< ±0.015 % FS/K
	Overload on one side P1 / P2	8 / 8 bar
	System pressure	25 bar (P1 and P2 simultaneously)
	Bursting pressure	37.5 bar (1.5 x system pressure)
	Dynamic response:	
	Response time	< 5 ms
	Load alternation	< 50 Hz
	Suitable media	Air, mildly corrosive gases, liquids
Admissible temperature of medium	-15...+85 °C	
Maintenance	No maintenance required	
Protective data	Protection standard	IP 65 to IEC 60 529
	Protection class	III according to EN 60 730
	Connections	
Connections	Connecting cable	3-core, 1.5 m long
	Cable entry	Cable gland
	Pressure connections	Male-threaded G ¹ / ₈ ", With screwed fittings for copper pipes, 6 mm diameter
Mountings	Mounting bracket	For mounting in ducts, on walls or ceilings and in control panels
	Orientation	Any (factory-calibrated with pressure connections at bottom). When used with liquids: Purging points at top
Environmental conditions	Perm. ambient temperature	
	Operation	-15...+85 °C
	Storage/Transport	-40...+85 °C
	Perm. ambient humidity	<90 % r. h. (non-condensing)
Directives and Standards	Electromagnetic compatibility	
	Immunity to	EN 61 000-6-2, EN 61 326-1
	Emissions to	EN 61 000-6-3, EN 61 326-1
	 conformity to EMC directive	2004/108/EC
	 C-Tick conformity (EMC)	EN 61 000-6-3
Environmental compatibility	Environmental product declaration	ISO 14001 (environment)
	CE1E1921en provides information on environmentally compatible product design and assessment (RoHS compliance, composition of substances, packaging, environmental benefit, disposal).	ISO 9001 (quality) SN 36350 (environ. compat. products) RL 2002/95/EG (RoHS)
Materials	Pressure casing, cover	Aluminium (AlMgSi1)
	Parts in contact with medium	Stainless steel (1.4305), ceramic element
	Sealant	FPM (fluoroelastomer)
	Mounting bracket	Stainless steel (1.4305)
	Mounting kit AQB2002	See "Accessories"
Weight	Including packaging	0.43 kg

Connection terminals

		<u>Color</u>	
G		Brown	Supply voltage AC 24 V or DC 18...33 V
U		Green	DC 0...10 V output signal (reference point GND)
M		White	GND

Dimensions

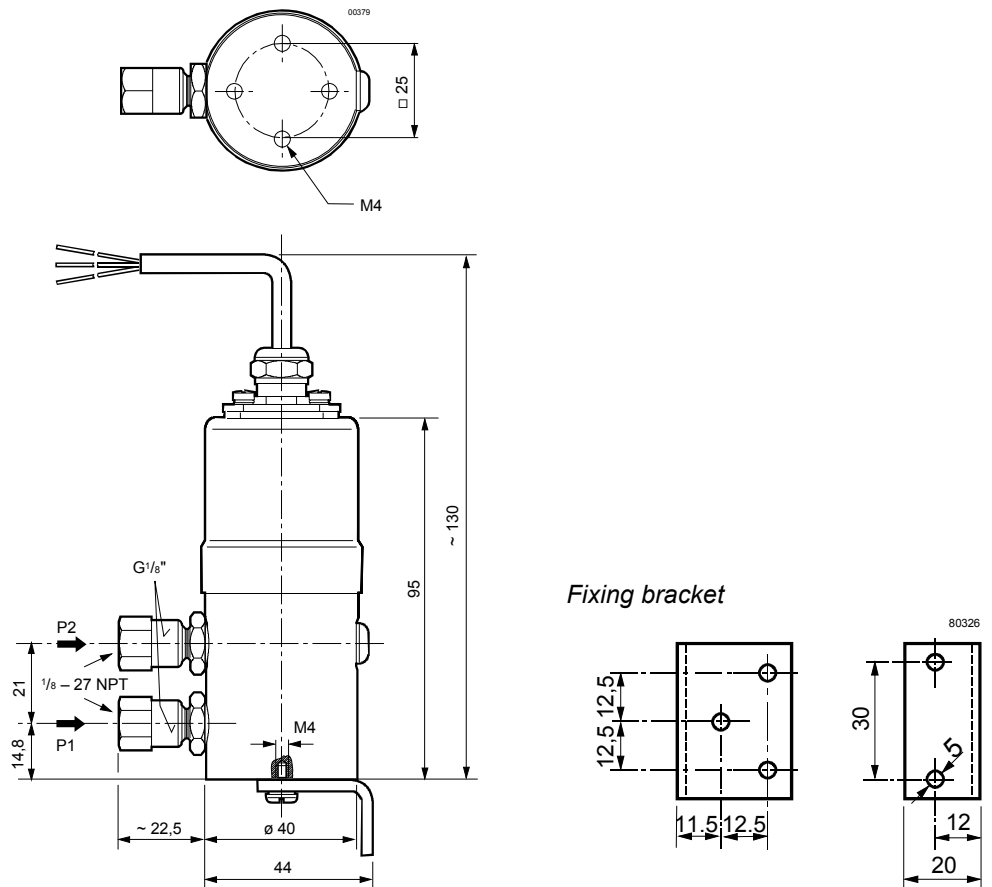

Dimensions in mm