



Synco™ 100

Immersion Temperature Controller

RLE162

with 2 outputs DC 0...10 V

Immersion temperature controller for water-side control in heating and cooling plants. Compact design with 2 analog control outputs DC 0...10 V for heating and/or cooling.

Use

Plant types:

- Ventilation or air conditioning plants
- Small heating plants
- DHW temperature
- Water-side control in HVAC plants
- Closed circuit heat exchanger
- Cooling water temperature

Building types:

- Small residential buildings
- Non-residential buildings of all types

Devices that can be controlled:

- Heating valve actuators
- Cooling valve actuators

Functions

- Main function**
- Modulating control of the water temperature through control of the actuating device with selectable operating action of the control signals for heating only or cooling only or heating and cooling (changeover)
- Other functions**
- Outside temperature compensation
 - Minimum limitation of the controlled temperature
 - Maximum limitation of the controlled temperature
 - Remote setpoint adjustment
 - Setpoint changeover via external contact
 - Load-dependent switching contact (e.g. pump release)
 - Test mode as a commissioning aid

Ordering

When ordering, please give type reference **RLE162**.

Accessories

If required, a protection pocket is available:

<i>Specifications</i>	<i>Type ref.</i>	<i>Data Sheet</i>
PN10, 150 mm immersion length, brass (Ms63)	ALT-SB150	N1193

Equipment combinations

Actuators and controls must meet the following specification:

- Control input: modulating, DC 0...10 V
- Operating voltage: AC 24 V

For auxiliary functions, the following products can be used:

<i>Type of unit</i>	<i>Type ref.</i>	<i>Data Sheet</i>
Outside sensor (for outside temperature compensation)	QAC22	N1811
Remote setpoint adjuster	BSG21.1	N1991
Scale 0...130 °C for remote setpoint adjuster	BSG-Z	N1991

Technical design

- Application**
- 1-stage heating
 - 1-stage cooling
 - 2-stage heating
 - 1-stage heating and 1-stage cooling

Temperature control

Settings

The following settings are required:

- Setpoint
- Operating action: the 2 control outputs Y1 and Y2 can act as follows:
 - 1-stage heating: control output Y2 is not used
 - 1-stage cooling: the second control output Y2 is not used
 - 2-stage heating: both control outputs have the same operating action and operate in sequence
 - 1-stage heating and 1-stage cooling: the control outputs have opposed operating actions (see section "Control of heating or cooling")
- Control mode: to match the controller to the type of controlled system, 4 choices are available:
 - P-mode
 - PI mode with a fixed integral action time of 240 seconds (SLOW)
 - PI mode with a fixed integral action time of 120 seconds (MEDIUM)

- PI mode with a fixed integral action time of 60 seconds (FAST); suited for fast controlled systems such as DHW temperature control
- P-band of control output Y1
- P-band of control output Y2

Control of heating or cooling

The RLE162 temperature controller compares the water temperature acquired by the sensor (integrated in the controller) with the setpoint. If there is a deviation, the controller generates a DC 0...10 V control signal to adjust the regulating unit(s) between 0...100 %. In P-mode, the output is proportional to the offset, in PI mode the output is proportional to the heating or cooling load.

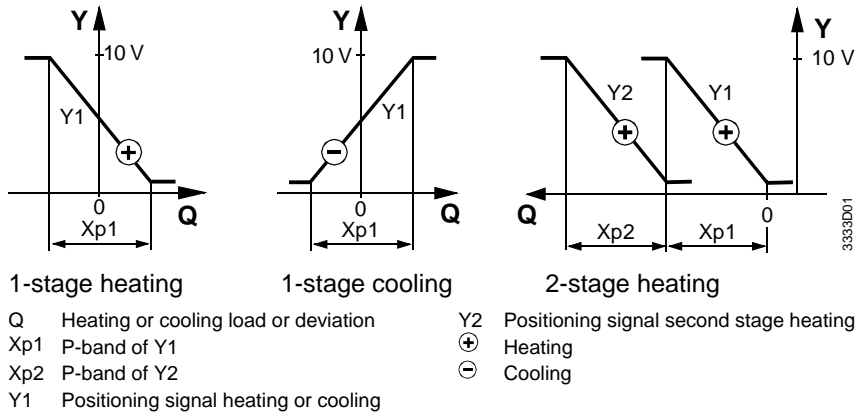

Control of heating and cooling

This kind of control is used exclusively with heat exchangers having a closed circuit with summer/winter changeover. Changeover of the control signals and the setpoint is accomplished via an external contact, such as a yearly time switch.

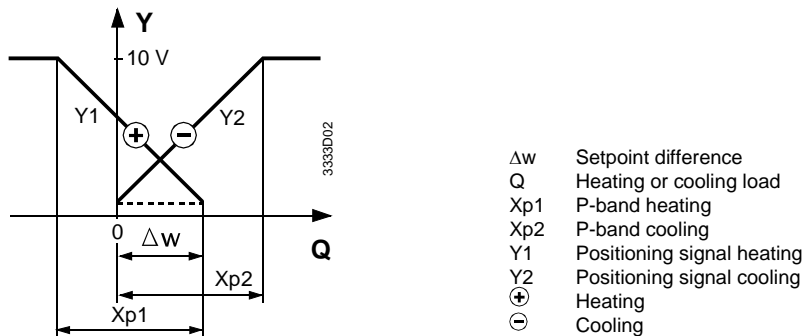

Example

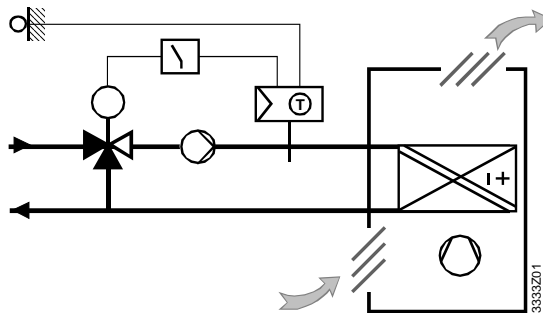

- Summer operation:
Setpoint of cooling water temperature is maintained via output Y2, adjustment made with the main slider, control output Y1 is deactivated via an external switch
- Winter operation:
Setpoint of heating flow temperature is maintained via output Y1, setpoint is raised to the changeover setpoint Δw via an time switch, which also deactivates control output Y2

Maximum and minimum limitation

The controller can be used as a high or low limiter. Its control signal is fed to the temperature controller. This means that the limiter takes over the control function when the selected limit value is reached, thus preventing a further increase or decrease of the water temperature (see chapter "Engineering notes").

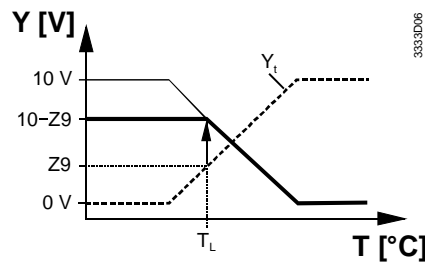

1-stage heating

Maximum limitation of the controlled temperature

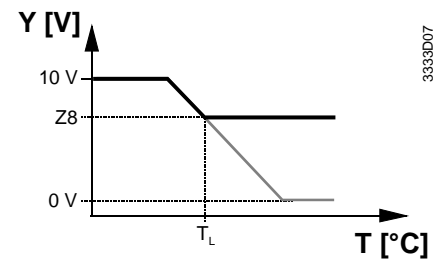

1-stage heating

Minimum limitation of the controlled temperature

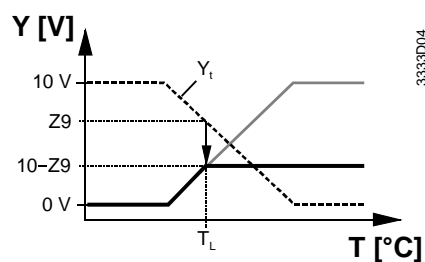

1-stage cooling

Minimum limitation of the controlled temperature through maximum limitation of the output for cooling

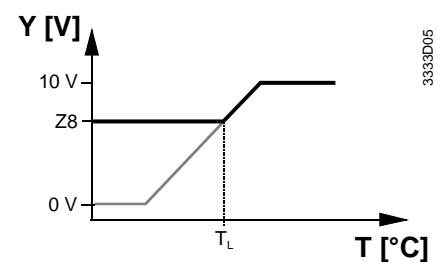

1-stage cooling

Maximum limitation of the controlled temperature through minimum limitation of the output for cooling

T	Controlled temperature
T_L	Limit temperature
Y	Positioning signal of controller
Y_t	Simulated positioning signal
Z8	Signal delivered to terminal Z8 by the limiter
Z9	Signal delivered to terminal Z9 by the limiter

Outside temperature compensation

When using an outside sensor, the current setpoint will be shifted depending on the outside temperature.

Outside temperature compensation only acts as winter compensation. It can only be provided in operating modes **1-stage heating** and **2-stage heating**. 2 ranges are available: LOW and HIGH. Within the selected range, compensation is based on fixed values. If the outside temperature falls from +15 °C to -5 °C, the setpoint will be continuously raised by 14 K (LOW) or 28 K (HIGH). Below an outside temperature of -5 °C, the temperature increase will be kept constant.

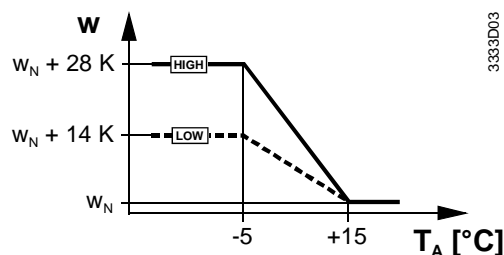

T_A	Outside temperature
w	Current setpoint
w_N	Nominal setpoint

Remote adjustment of setpoint

Where the controller is mounted in an inaccessible location, a remote setpoint adjuster BSG21.1 can be connected to the RLE162 (terminals R1–M), thus enabling the setpoint to be adjusted from a remote location. In this case, the controller's setpoint setting slider must be set to EXT.

Setpoint changeover

Changeover of the nominal setpoint is accomplished by closing an external potential-free contact across terminals D1–M, aimed at saving energy.

The effect is the following, depending on the operating mode:

- **1-stage heating:** setpoint will be **lowered**
- **1-stage cooling:** setpoint will be **raised**
- **2-stage heating:** setpoint will be **lowered**
- **1-stage heating and 1-stage cooling in sequence:** setpoint will be **raised** (refer to section “Control of heating and cooling”)

A slider is provided to set the temperature by which the nominal setpoint shall be lowered or raised. The setting cannot be accessed by the user.

Legionella protection

In operating mode **1-stage heating and 1-stage cooling in sequence**, the nominal setpoint can be raised by closing an external potential-free contact across terminals D1–M. This makes possible legionella protection in DHW heating systems. With the help of a 7-day time switch, the DHW is periodically heated up to the required temperature. The setting cannot be accessed by the user.

Switching contact

The switching output (terminals Q13–Q14) enables a plant element to be switched depending on the heating or cooling load.

The switching contact is controlled by control signal Y1. If the heating or cooling load exceeds 5 % of the correcting span of Y1 (DC 0.5 V), the contact will make. The contact breaks, when there is no demand (0 %) for a period of 12 minutes.

Test mode

In test mode, the control is switched off. The setpoint setting knob acts as a positioning unit to manually drive the actuating device (or both actuating devices) to any position required. The positioning range in test mode is configured to match the selected operating mode. The test mode is indicated by an LED.

Mechanical design

The controller is designed for direct mounting into piping. It consists of housing and cover, a threaded nipple and an immersion rod. The rod contains the sensing element (LG-Ni 1000).

The housing is made of plastic and accommodates the controller electronics and all operating elements, which are accessible only after removing the cover. The front carries the setpoint setting slider and an LED for indicating operation:

- LED lit: normal operation
- LED flashes: test mode

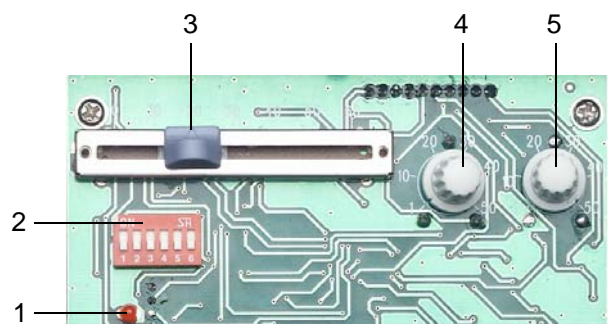

- 1 LED
- 2 Block of DIP switches
- 3 Setting slider for the setpoint increase or decrease
- 4 Setting potentiometer for the P-band Y2
- 5 Setting potentiometer for the P-band Y1

For mounting, the controller provides a threaded nipple with a fixing nut. The controller is fitted into the pipe without using a protection pocket, but a pocket can also be fitted, if required.

All functions are selected via the DIP switch block which comprises 6 switches:

Function	1	2	3	4	5	6	Action
Operating mode	<input type="checkbox"/>	<input type="checkbox"/>					Heating and cooling in sequence
	<input type="checkbox"/>	<input type="checkbox"/>					2-stage heating
	<input type="checkbox"/>	<input type="checkbox"/>					1-stage cooling
	<input type="checkbox"/>	<input type="checkbox"/>					1-stage heating
Control mode			<input type="checkbox"/>	<input type="checkbox"/>			P
			<input type="checkbox"/>	<input type="checkbox"/>			PI, integral action time = 120 s (MEDIUM)
			<input type="checkbox"/>	<input type="checkbox"/>			PI, integral action time = 240 s (SLOW)
			<input type="checkbox"/>	<input type="checkbox"/>			PI, integral action time = 60 s (FAST)
Test mode					<input type="checkbox"/>		Test mode
					<input type="checkbox"/>		Normal operation
Outside temperature compensation						<input type="checkbox"/>	HIGH
						<input type="checkbox"/>	LOW

Engineering notes

In the event of a power failure, the actuating device will automatically close or be driven into the neutral position.

If a protection pocket is used, the sensor's time constant will become greater.
The controller is supplied complete with Mounting and Installation Instructions.

Mounting notes

The controller is to be fitted directly to the pipe. Ensure that the local safety regulations are complied with.

Suitable mounting locations are the following, depending on the application:

- Flow temperature control:
 - In the heating flow; immediately after the pump if the pump is mounted in the flow
 - In the heating flow; approximately 1.5 to 2 m after the mixing point if the pump is mounted in the return
- Return temperature control:
 - 1 to 1.5 m after the mixing point
- Minimum limitation of the boiler return temperature and maximum limitation of the flow temperature:
 - 1.5 to 2 m after the mixing point
- DHW temperature control:
 - 1.5 to 2 m after the mixing point
- Heat exchanger control:
 - As close as possible to the heat exchanger while observing the maximum permissible ambient temperature

To mount the controller (or the protection pocket), a threaded sleeve must be fitted into the pipe. The immersion rod should face the direction of flow if possible. The maximum permissible ambient temperature must be observed.

Commissioning notes

To check the control wiring, the controller can be switched into test mode so that the response of the actuating device can be checked.

In case of instability of the control loop, the P-band is to be increased, and with PI-control, the integral action time selection. If the response of the system is too slow, these values are to be reduced.

Technical data

Power supply	Operating voltage	AC 24 V \pm 20 %
	Frequency	50 / 60 Hz
	Power consumption	max. 2 VA
Functional data	Setting range nominal setpoint	-10...+130 °C
	Setting range setpoint changeover	0...60 K
	P band Y1	1...50 K
	P band Y2	1...50 K
	Integral action time with PI control	selectable (60 / 120 / 240 s)
	Control outputs Y1, Y2	
	Voltage	DC 0...10 V, modulating
	Current	max. 1 mA
	Control outputs (Q13-Q14)	
	Voltage	AC 24...230 V
	Current	max. 2 A
	Max. cable length copper cable 1.5 mm ²	
	For signal input B9	80 m
For switching input D1	80 m	
Contact sensing (input D1-M)	DC 6...15 V, 3...6 mA	
Environmental conditions	Operation	
	Climatic conditions	to IEC 721-3-3, class 3K5
	Temperature	0...+50 °C
	Humidity	<95 % r.h.
	Transport	
	Climatic conditions	to IEC 721-3-2, class 2K3
	Temperature	-25...+70 °C
	Humidity	<95 % r.h.
	Mechanical conditions	class 2M2
	Norms and standards	CE conformity according to
EMC directives		89/336/EEC
Low voltage directives		73/23/EEC and 93/68/EEC
Product standards		
Automatic electrical controls for household and similar use		EN 60730-1 and EN 60730-2-9
Electromagnetic compatibility		
Emissions		EN 50081-1
Immunity		EN 50082-1
Degree of protection		IP65 EN 60529
Safety class		II to EN 60730
Degree of contamination		normal
General	Connection terminals for solid wires or stranded wires	2 x 1.5 mm ² or 1 x 2.5 mm ²
	Perm. nominal pressure	PN10
	Sensor	
	Sensing element	LG-Ni 1000 Ω at 0 °C
	Time constant	6 s (or 30 s with protection pocket)
	Immersion rod	stainless steel pipe to DIN 17440
	Threaded nipple	steel 1.4404, 1.4435, 1.4571, G $\frac{1}{2}$ A
Weight	0.3 kg	

Connection terminals

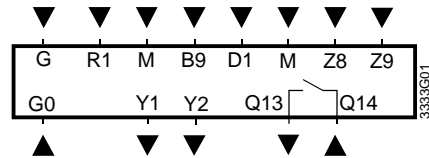

B9	Outside sensor
D1	Input for setpoint changeover
G	Operating voltage AC 24 V, system potential SP
G0	Operating voltage AC 24 V, system neutral SN
M	Ground
R1	Input for remote setpoint adjuster
Q13	Switching contact
Q14	Switching contact
Y1	Control output DC 0...10 V
Y2	Control output DC 0...10 V
Z8	Limitation input DC 0...10 V
Z9	Limitation input DC 0...10 V

Connection diagrams

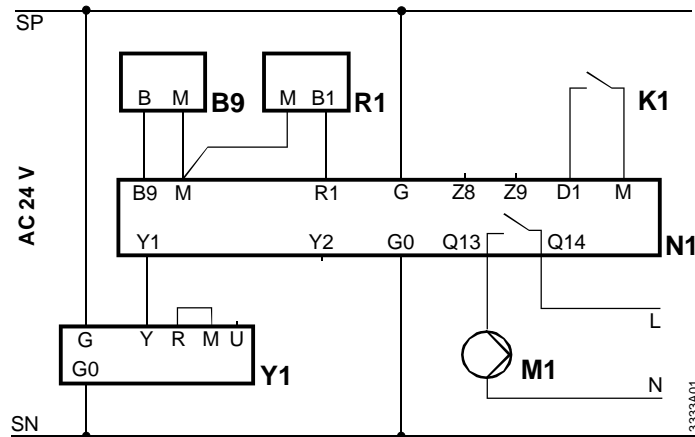

Flow temperature control with outside temperature compensation, remote setpoint adjuster, setpoint changeover and demand control of a pump

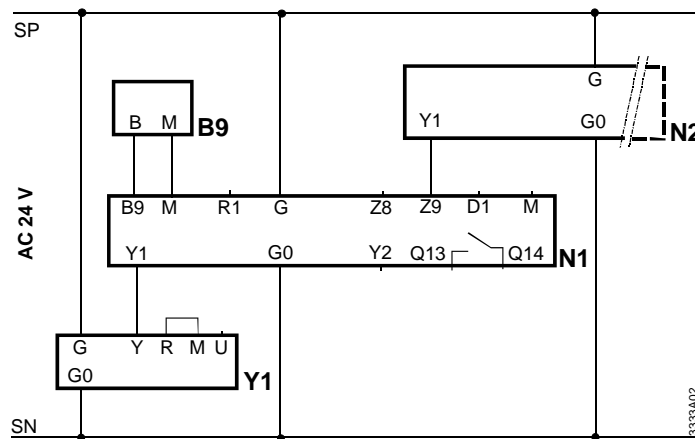

Flow temperature control, outside temperature compensation and maximum limitation of the flow temperature

B9	Outside sensor QAC22
K1	External contact (e.g. time switch)
M1	Pump
N1	Immersion temperature controller RLE162 (as a flow temperature controller)
N2	Immersion temperature controller RLE162 (as a flow temperature limiter)
R1	Remote setpoint adjuster BSG21.1
Y1	Heating valve actuator

Application examples

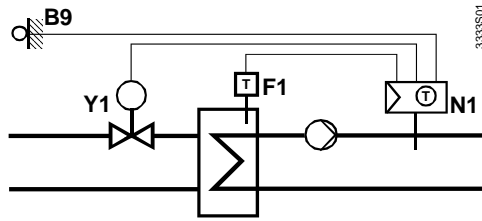

Heat exchanger control through control of the 2-port valve in the primary flow, outside temperature compensation

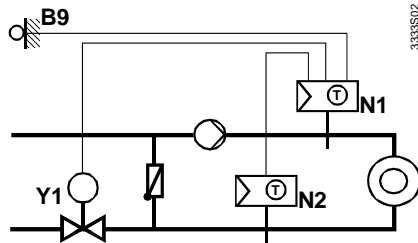

Flow temperature control with maximum limitation of the secondary return temperature in a district heat plant, outside temperature compensation

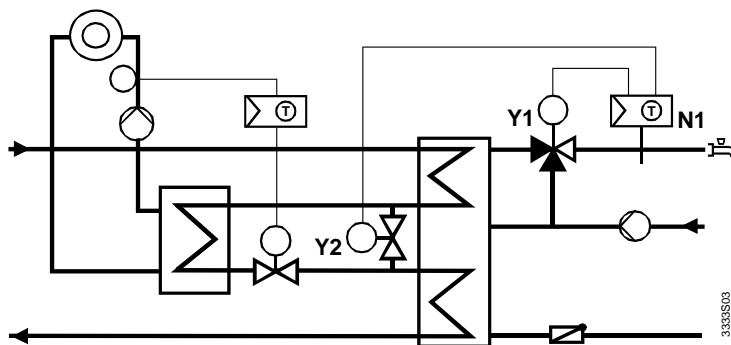

Direct DHW heating via heat exchanger, Y1 controls the mixing valve in the DHW circuit, Y2 controls the 2-port valve for DHW priority

- B9 Outside sensor QAC22
- F1 Safety limit thermostat
- N1 Immersion temperature controller RLE162
- N2 Immersion temperature controller RLE162 as a limiter
- Y1 Heating valve or DHW mixing valve
- Y2 Bypass 2-port valve

Dimensions

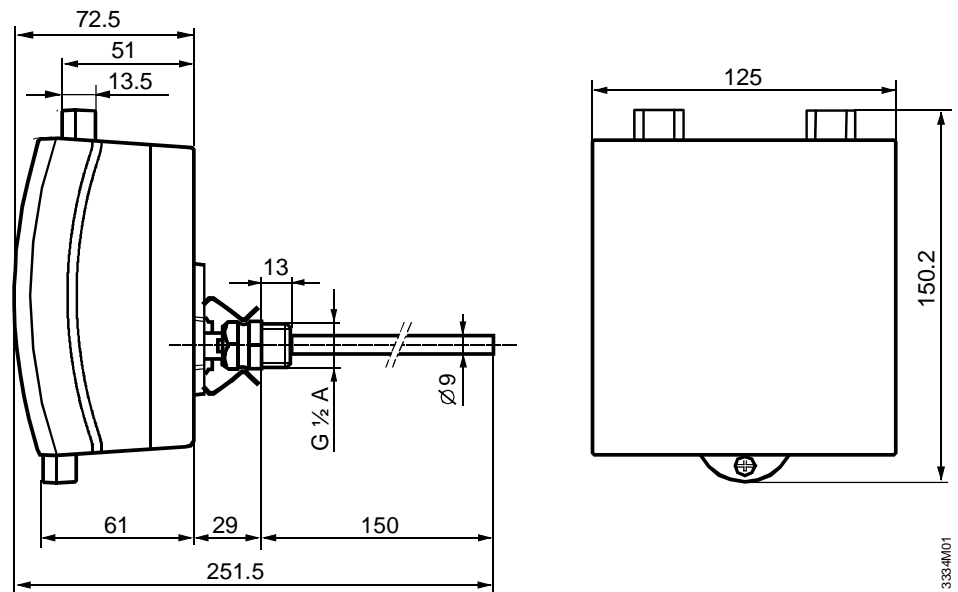

Dimensions in mm